

La liste de courses

Objectifs : mémoriser une liste d'objets et la restituer

Nombres de joueurs de 1 à 4 (ou plus)

Photocopier 4 caddies (ou plus selon le nombre de joueurs) , la liste des courses en 1 ou 2 exemplaires selon que vous l'utiliser en individuel ou en groupe., les cartes objets en 1 ou 3 exemplaires en fonction du nombre de caddies , plastifier et découper.

Chaque enfant choisit une liste de course, la mémorise. Laisser le temps nécessaire surtout au début (peu à peu ce temps peut-être diminué ou imposé). Retourner la liste de course L'enfant prend les différents éléments présents sur sa liste de course et les place dans son caddie (l'ordre n'a pas d'importance). Si l'on joue à plusieurs l'enfant qui a mémorisé le plus d'éléments de son caddie gagne une carte cadeau. Amener les enfants à développer des stratégies de mémorisation (se raconter une histoire avec les différents objets, les associer deux par deux , les grouper par catégorie ...)

Autres variantes :

Lorsque l'on joue à plusieurs , on peut avoir une même liste de course pour tous les joueurs mais dans ce cas, veiller à ce qu'ils ne puissent pas voir les caddies de leurs voisins. Celui qui a été le plus rapide et qui a mémorisé le maximum d'éléments à gagné.

développer la mémoire visuelle (les enfants voient la liste de course) ou seulement la mémoire auditive (l'enseignant lit la liste de course sans que les enfants la voient).

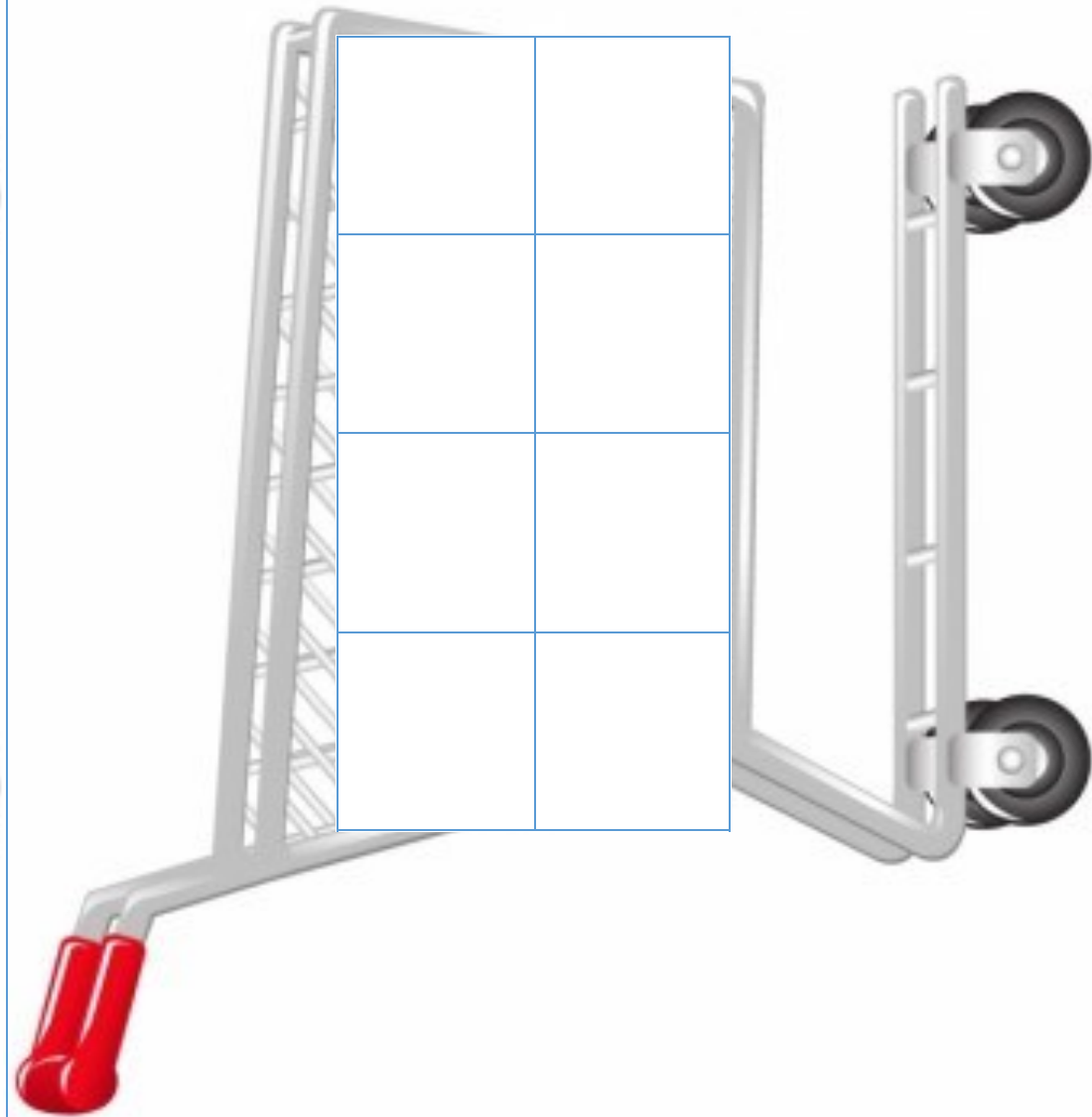
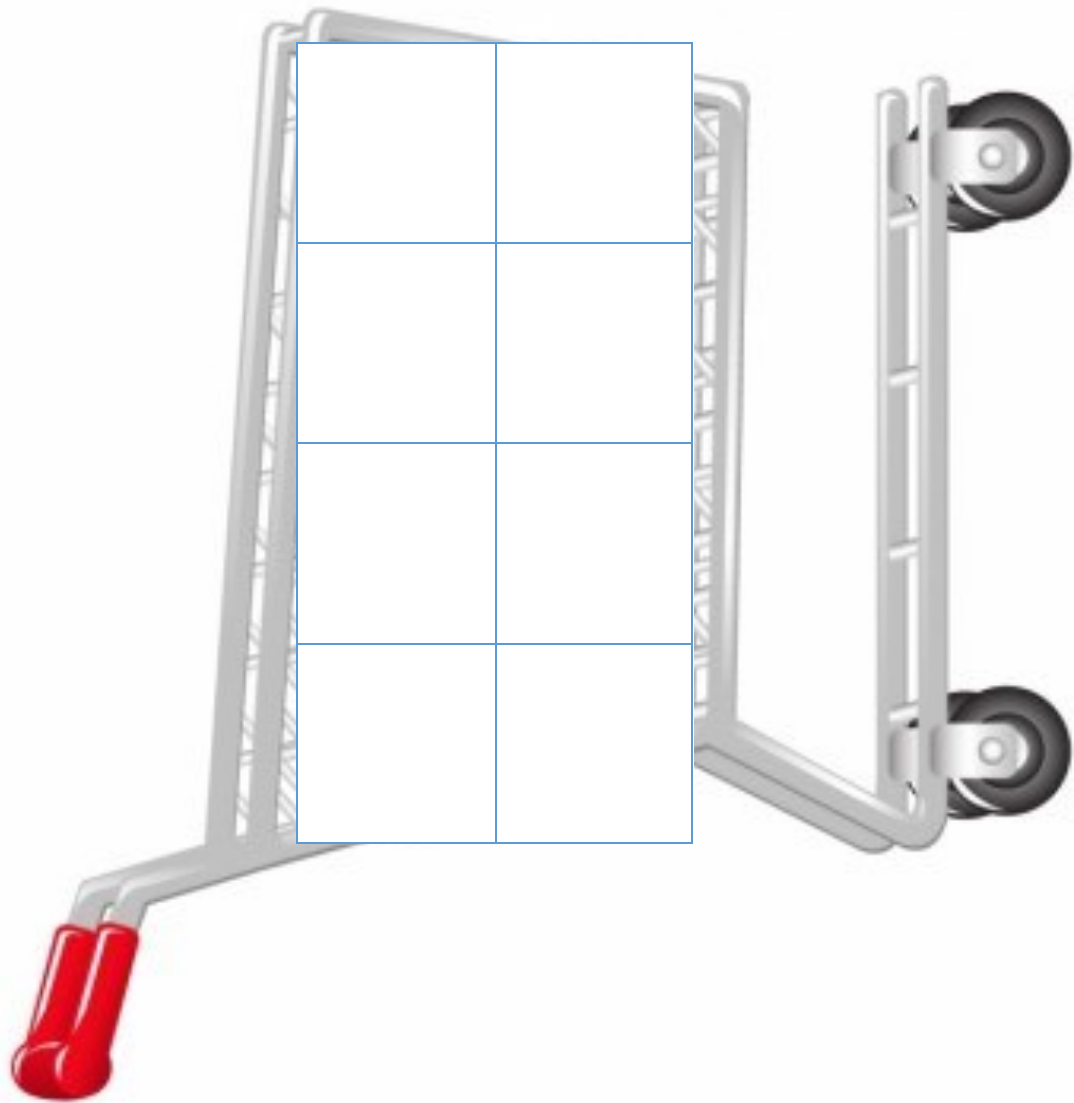

La liste de mes courses ①

un gilet



une ampoule



une poupée



un tambourin

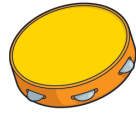

une paire de



ciseaux

du beurre

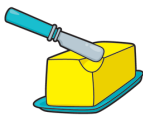

un citron



un pull



La liste de mes courses ②

une glace



du fromage

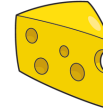

des carottes



une scie



un croissant



une règle

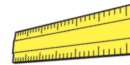

un biberon



une lampe de



chevet

La liste de mes courses ③

une paire de



chaussures

des fraises



un surligneur



des spaghettis



un avocat



des oeufs



des abricots



des poires



La liste de mes courses ④

un parapluie



du savon



des bananes



des radis



une montre



un manteau



un bonnet



du soda



La liste de mes courses ⑤

une flûte



une écharpe



une gomme



des haricots



verts

un gâteau



du lait



du riz



du raisin



La liste de mes ⑥

des tulipes

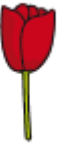

des tomates



un balai



du boudin noir



un sandwich



du sucre



du jus d'orange



de la farine



La liste de mes courses ⑦

des roses



une trousse



des feutres



des billes



de la colle



une raquette



un chapeau



des cerises



La liste de mes ⑧

un ananas



une brosse à



cheveux

des noisettes



un poulet



un taille-crayon

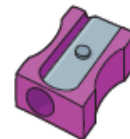

des yaourts



du pain



un marteau



La liste de mes courses ⑨

une ampoule



des carottes



un croissant



des fraises



des abricots



des billes



un ananas



une écharpe



